

# Driver seat KFS 12



The crane driver`s seat KFS 12 is ergonomically designed and provides a high grade of comfort. The driver`s seat is equipped with an air-sprung vibration system. The weight adjustment is infinitely. Heated seats 24V, lumbar support, seat cushion adjustment, seat allocation recognition and headrest are included in the standard delivery. All adjustment controls are positioned ergonomically within easy access. The metal parts are protected against corrosion and painted black.



## Technical data:

Suspension stroke	80mm
Weight adjustment	50 - 150kg
Horizontal adjustment	230mm
Inclination of the backrest	-12° / +40°
Slope adjustment	-10° / +12°
Height adjustment	100mm
Seat cushion adjustment	60mm

Example

	KFS 12	- A1	- S1
<b>Driver seat</b>			
KFS 12 Driver seat with textile cover grey / black			
<b>Attachments</b>			
A1 Armrest adjustable (2 pieces) 50mm wide			
A2 Armrest continuously adjustable (2 pieces) 100mm wide			
S1 Safety belt 2 point fixing (automatic)			
S3 Safety belt 2 point fixing (static)			
LK Plate for horizontal manual adjustment of seat adjustable +/-250mm			
C4 Loose cover for driver seat KFS 11 / KFS 12			
U Console (base)			

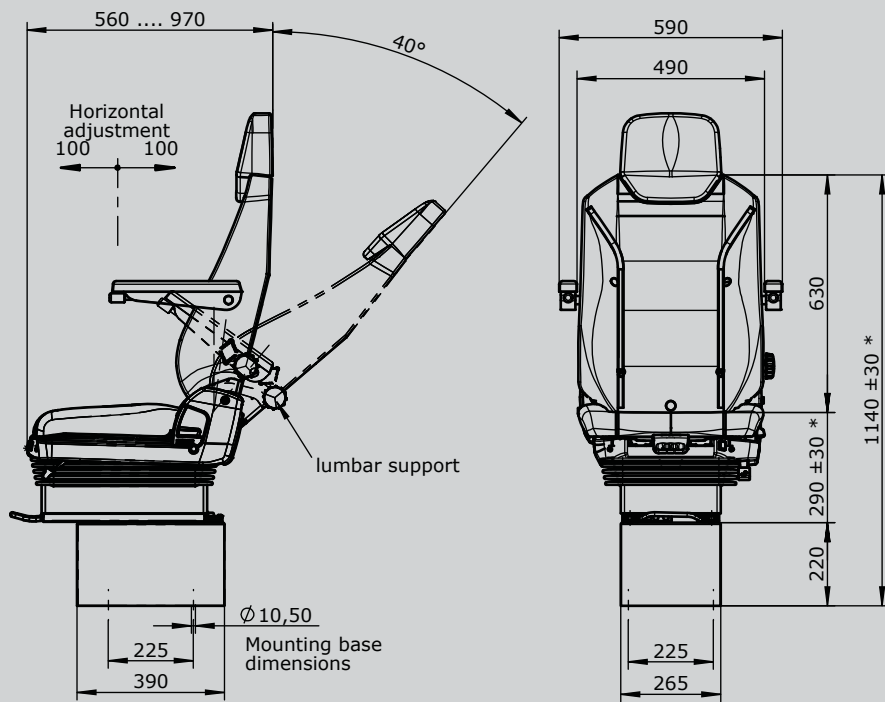

Special equipment

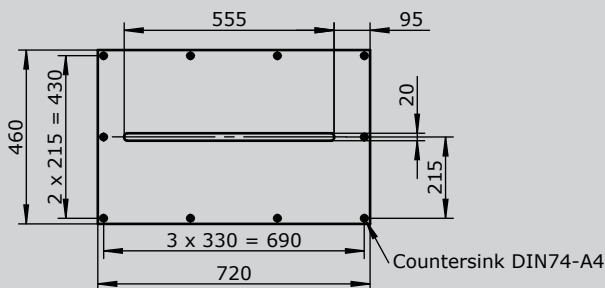
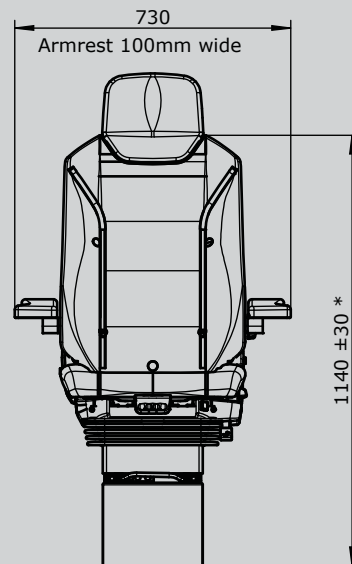
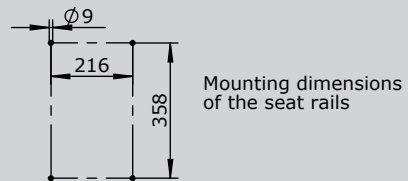
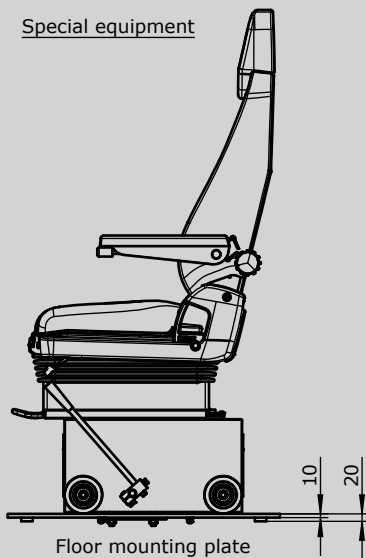

\* adjustable