

# Driver seat KFS 11



The crane driver`s seat KFS 11 is ergonomically designed and provides a high grade of comfort.  
The driver`s seat is a low level mechanical suspension seat with an oil-hydraulic vibration absorption system with weight adjustment.  
All adjustment controls are positioned ergonomically within easy access.  
The metal parts are protected against corrosion and painted black.

## Technical data

Suspension stroke	80mm
Weight adjustment	50 - 150kg
Horizontal adjustment	230mm
Inclination of the backrest	-12°/+40°
Slope adjustment	-10°/+12°
Height adjustment	65mm



Example

	KFS 11	- A1	- S1
<b>Driver seat</b>			
KFS 11	Driver seat with textile cover grey / black		
<b>Attachments</b>			
K	Headrest		
A1	Armrest adjustable (2 pieces) 50mm wide		
A2	Armrest continuously adjustable (2 pieces) 100mm wide		
H	Seat cushion and backrest with heating element 24V DC 47W		
S1	Safety belt 2 point fixing (automatic)		
S3	Safety belt 2 point fixing (static)		
LK	Plate for horizontal manual adjustment of seat adjustable +/-250mm		
C4	Loose cover for driver seat KFS 11 / KFS 12		
U	Console (base)		

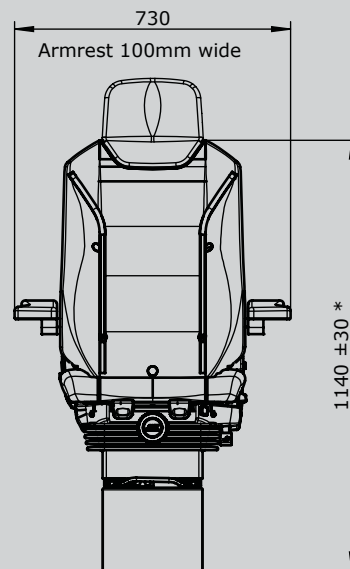
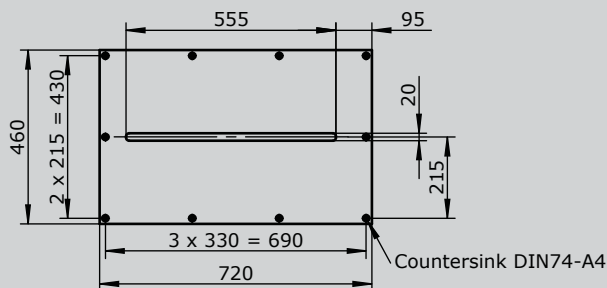
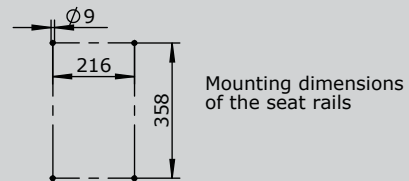
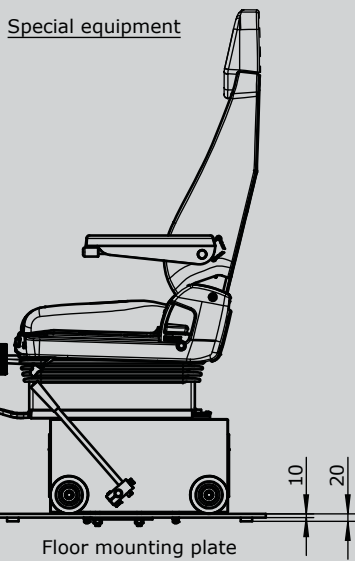
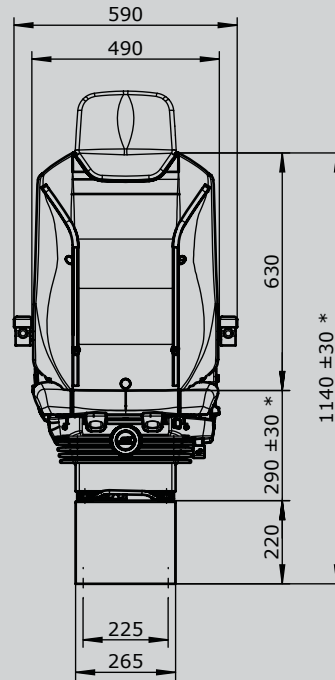
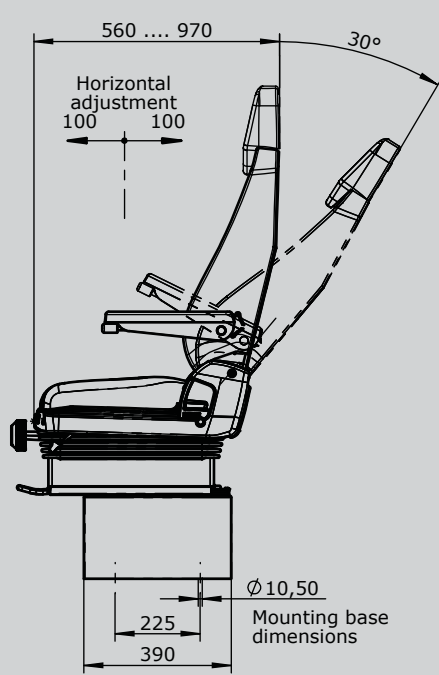

\* adjustable