

# Absolute encoders - singleturn

**Standard  
Motor-Line, optical**

**Sendix 5873 (tapered shaft)**

**SSI / BiSS + incremental**

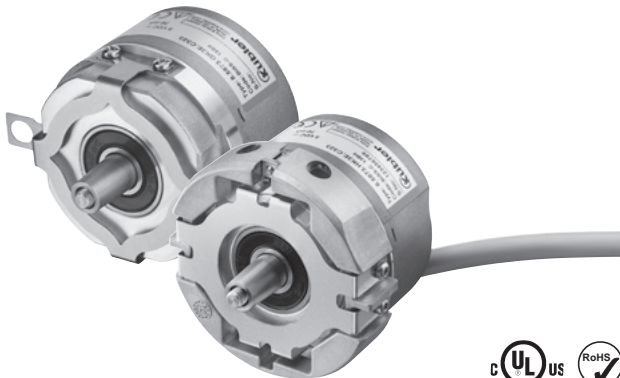

The optical Sendix 5873 singleturn encoders with SSI or BiSS interface and optional 2048 ppr SinCos incremental track reach a resolution of up to 21 bits.

**Advantages: Plug-and-Play for commissioning, including electronic data sheet and possibility to set the absolute measuring system to a predefined position value.**

**Specially designed for mounting on direct drives in the elevator technology.**



Electronic data sheet



Safety-Lock™

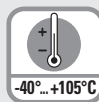

Temperature range  
-40°...+105°C



High protection level  
IP



High shaft load capacity



Shock / vibration resistant



Magnetic field proof



Short-circuit proof



Reverse polarity protection

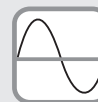

SinCos



Optical sensor

## Reliable and insensitive

- Sturdy bearing construction in Safety-Lock™ design for resistance against vibration and installation errors.
- Encoder specially designed for mounting on direct drives in the elevator technology.

## Versatile

- High-precision with a data refresh rate of the position value  $\leq 1 \mu\text{s}$ .
- High-resolution feedback in real-time via 21 bit fully digital or incremental outputs SinCos and RS422.
- BiSS-C BP3 encoder profile.
- Short control cycles, clock rate with SSI up to 2 MHz / with BiSS up to 10 MHz.

## Order code Tapered shaft

**8.5873** . **XKXX** . **XX2X**  
Type      a b c d e f g

### a Flange

G = with stator coupling, IP65,  $\varnothing$  72 mm [2.83"]  
H = with expanding coupling, IP65,  $\varnothing$  65 mm [2.56"]

### b Tapered shaft

K =  $\varnothing$  10 mm [0.39"]

### c Interface / power supply

1 = SSI, BiSS / 5 V DC  
2 = SSI, BiSS / 10 ... 30 V DC  
3 = SSI, BiSS + 2048 ppr. SinCos / 5 V DC  
4 = SSI, BiSS + 2048 ppr. SinCos / 10 ... 30 V DC  
5 = SSI, BiSS / 5 V DC, with sensor output  
6 = SSI, BiSS + 2048 ppr. SinCos / 5 V DC, with sensor output  
9 = SSI, BiSS + 2048 ppr. RS422 (TTL-comp.) / 5 V DC, with sensor output  
E = SSI, BiSS + 2048 ppr. SinCos / 4.5 ... 5.5 V DC, with sensor output<sup>1)</sup>

### d Type of connection

E = tangential cable, 1 m PVC  
F = tangential cable, length PVC see below \*)  
G = tangential cable, with Sub-D connector (male contact, 15-pin, double-row), length PVC s. below \*)<sup>2)</sup>  
H = tangential cable, with Phoenix Contact connector (MC1.5/16-STF-3.81), length PVC s. below \*)<sup>2)</sup>  
L = with PCB connector<sup>3)</sup>  
(without cable, including sealing cap for tangential cable outlet)

\*) Available lengths (connection types F, G, H):  
2, 3, 5, 8, 10, 15 m [5.56, 9.84, 16.40, 26.25, 32.80, 49.21']  
order code expansion .XXXX = length in dm  
ex.: 8.5873.GK2E.G323.0030 (for cable length 3 m)

### e Code

B = SSI, binary  
C = BiSS, binary  
G = SSI, gray

### f Resolution<sup>4)</sup>

A = 10 bit  
1 = 11 bit  
2 = 12 bit  
3 = 13 bit  
4 = 14 bit  
7 = 17 bit  
C = 21 bit<sup>5)</sup>

### g Options (service)

1 = no option  
2 = status LED  
3 = SET button and status LED

1) Without reverse polarity protection.

2) Can be combined as a standard only with interface E (other variants on request).

3) IP40, only available without SET button and status LED, not available with interface 9, see the Accessories for the suitable connection cable.

4) Resolution, preset value and counting direction factory-programmable.

5) Only in conjunction with interface 1 or 2 and code C.

# Absolute encoders - singleturn

Standard Motor-Line, optical	Sendix 5873 (tapered shaft)	SSI / BiSS + incremental
<b>Connection technology</b>		Order no.
<b>Cordset, pre-assembled</b> (suitable for type of connection L)	PCB connector (female contacts), 12-pin single-ended, 2 m [6.56'] PVC cable	<b>8.0000.6D91.0002</b>
	PCB connector (female contacts), 12-pin single-ended, 8 m [26.25'] PVC cable	<b>8.0000.6D91.0008</b>

Additional connectors can be found in the connection technology section or in the connection technology area of our website at: [www.kuebler.com/connection\\_technology](http://www.kuebler.com/connection_technology).

## Technical data

Mechanical characteristics	
<b>Maximum speed</b>	IP65 up to 70°C [158°F] 12000 min <sup>-1</sup> , 10000 min <sup>-1</sup> (continuous) IP65 up to T <sub>max</sub> 8000 min <sup>-1</sup> , 5000 min <sup>-1</sup> (continuous)
<b>Starting torque at 20°C [68°F]</b>	< 0.01 Nm
<b>Mass moment of inertia</b>	3.0 x 10 <sup>-6</sup> kgm <sup>2</sup>
<b>Load capacity of shaft</b>	radial 80 N axial 40 N
<b>Weight</b>	approx. 0.35 kg [12.35 oz]
<b>Protection acc. to EN 60529</b>	IP65
<b>Working temperature range</b>	-40°C ... +90°C [-40°F ... +194°F] (+105°C [+212°F] with interface E) <sup>1)</sup>
<b>Materials</b>	tapered shaft stainless steel flange aluminum housing zinc die-cast cable PVC
<b>Shock resistance acc. EN 60068-2-27</b>	2500 m/s <sup>2</sup> , 6 ms
<b>Vibration resistance acc. EN 60068-2-6</b>	100 m/s <sup>2</sup> , 55 ... 2000 Hz

Electrical characteristics	
<b>Power supply</b>	5 V DC (+5 %) 4.5 ... 5.5 V DC or 10 ... 30 V DC
<b>Current consumption (no load)</b>	5 V DC max. 70 mA 10 ... 30 V DC max. 45 mA
<b>Reverse polarity protection of the power supply</b>	yes (not for interface E)
<b>Short circuit proof outputs</b>	yes <sup>2)</sup>
<b>UL approval</b>	file 224618
<b>CE compliant acc. to</b>	EMC guideline 2014/30/EU RoHS guideline 2011/65/EU

SSI interface	
<b>Output driver</b>	RS485 transceiver type
<b>Permissible load / channel</b>	max. +/- 20 mA
<b>Signal level</b>	HIGH typ. 3.8 V LOW at I <sub>Load</sub> = 20 mA typ. 1.3 V
<b>Resolution</b>	10 ... 14 bit and 17 bit
<b>Code</b>	binary or gray
<b>SSI clock rate</b>	50 kHz ... 2 MHz
<b>Data refresh rate</b>	ST resolution ≤ 14 bit ≤ 1 μs ST resolution ≥ 15 bit 4 μs
<b>Monoflop time</b>	≤ 15 μs
<b>Note:</b> If the clock starts cycling within the monoflop time, a second data transfer starts with the same data. If the clock starts cycling after the monoflop time, the data transfer starts with the new values. The update rate is dependent on the clock speed, data length and monoflop-time.	

BiSS interface	
<b>Output driver</b>	RS485 transceiver type
<b>Permissible load / channel</b>	max. +/- 20 mA
<b>Signal level</b>	HIGH typ. 3.8 V LOW at I <sub>Load</sub> = 20 mA typ. 1.3 V
<b>Resolution</b>	10 ... 14 bit; 17, 19 and 21 bit
<b>Code</b>	binary
<b>Clock rate</b>	50 kHz ... 10 MHz
<b>Max. update rate</b>	< 15 μs, depends on the clock rate and the data length
<b>Data refresh rate</b>	ST resolution ≤ 14 bit ≤ 1 μs ST resolution 17 bit 2.4 μs ST resolution 21 bit 4 μs
<b>Protocol</b>	BiSS-C BP3 encoder profile
<b>Note:</b> <ul style="list-style-type: none"> <li>- Bidirectional, factory programmable parameters are: resolution, code, direction, alarms and warnings</li> <li>- CRC data verification</li> <li>- EDS (electronic data sheet)</li> </ul>	

1) Temperature measured on the flange – max. 80°C allowable on the cable (fixed installation).  
2) Short circuit to 0 V or to output, one channel at a time, power supply correctly applied.

# Absolute encoders - singleturn

<b>Standard Motor-Line, optical</b>	<b>Sendix 5873 (tapered shaft)</b>	<b>SSI / BiSS + incremental</b>
-------------------------------------	------------------------------------	---------------------------------

Status output and LED	
<b>Output driver</b>	open collector, internal pull up resistor 22 kOhm
<b>Permissible load</b>	max. 20 mA
<b>Signal level</b>	HIGH +V LOW < 1 V
<b>Active</b>	LOW
The optional LED (red) and the status output serve to display various alarm or error messages. In normal operation the LED is OFF and the status output is HIGH (Open Collector with int. pull-up 22 kOhm).	
An active status output (LOW) displays: <ul style="list-style-type: none"> <li>- Sensor error, singleturn or multiturn (soiling, glass breakage etc.)</li> <li>- LED fault (failure or ageing)</li> <li>- over- or under-temperature</li> </ul>	
In the SSI mode, the fault indication can only be reset by switching off the power supply to the device.	

Option incremental outputs (A/B), 2048 ppr		
	SinCos	RS422 TTL compatible
<b>Max. frequency -3dB</b>	400 kHz	400 kHz
<b>Signal level</b>	1 Vpp (±20 %)	HIGH: min. 2.5 V LOW: max. 0.5 V
<b>Short circuit proof</b>	yes	yes

SET input or SET button	
<b>Input</b>	active HIGH
<b>Input type</b>	comparator
<b>Signal level</b>	HIGH min: 60 % of +V (power supply) max: +V LOW max: 25 % of +V (power supply)
<b>Input current</b>	< 0.5 mA
<b>Min. pulse duration (SET)</b>	10 ms
<b>Timeout after SET signal</b>	14 ms
The encoder can be set to zero at any position by means of a HIGH signal on the SET input or by pressing the optional SET button (with a pencil, ball-point pen or similar). Other preset values can be factory-programmed. The SET input has a signal processing time of approx. 1 ms. Once the SET function has been triggered, the encoder requires an internal processing time of approx. 15 ms before the new position data can be read. During this time the status output is at LOW. If this input is not used, it should be connected to 0 V (Encoder ground GND) in order to avoid interferences.	
Note: In case of use of the BiSS interface, the SET function is carried out through BiSS.	

DIR input	
Direction input: A HIGH signal switches the direction of rotation from the default cw to ccw. This function can also be factory-programmed to be inverted. If DIR is changed when the device is already switched on, then this will be interpreted as an error. The LED will come ON and the status output will switch to LOW. If this input is not used, it should be connected to 0 V (Encoder ground GND) in order to avoid interferences.	
<b>Response time (DIR input)</b>	1 ms

Power-ON	
After Power-ON the device requires a time of approx. 150 ms before valid data can be read.	
Hot plugging of the encoder should be avoided.	

# Absolute encoders - singleturn

<b>Standard Motor-Line, optical</b>	<b>Sendix 5873 (tapered shaft)</b>	<b>SSI / BiSS + incremental</b>
-------------------------------------	------------------------------------	---------------------------------

## Terminal assignment

Interface	Type of connection	Features	Cable (isolate unused wires individually before initial start-up)
1, 2	E, F	SET, DIR, Status	Signal: 0 V +V C+ C- D+ D- SET DIR Stat N/C N/C N/C $\perp$
			Core color: WH BN GN YE GY PK BU RD BK - - - shield
Interface	Type of connection	Features	Cable (isolate unused wires individually before initial start-up)
5	E, F	SET, DIR, Status sensor output	Signal: 0 V +V C+ C- D+ D- SET DIR Stat N/C 0Vsens +Vsens $\perp$
			Core color: WH BN GN YE GY PK BU RD BK - GY-PK RD-BU shield
Interface	Type of connection	Features	Cable (isolate unused wires individually before initial start-up)
3, 4	E, F	SET, DIR, SinCos or incr. RS422	Signal: 0 V +V C+ C- D+ D- SET DIR A $\bar{A}$ B $\bar{B}$ $\perp$
			Core color: WH BN GN YE GY PK BU RD BK VT GY-PK RD-BU shield
Interface	Type of connection	Features	Cable (isolate unused wires individually before initial start-up)
6, 9, E	E, F	SinCos or incr. RS422 sensor output	Signal: 0 V +V C+ C- D+ D- A $\bar{A}$ B $\bar{B}$ 0Vsens +Vsens $\perp$
			Core color: WH BN GN YE GY PK BU RD BK VT GY-PK RD-BU shield
Interface	Type of connection	Features	Tangential cable, with Phoenix Contact connector (MC1.5/16-STF-3.81), 16-pin
E	H	SinCos sensor output	Signal: +V +Vsens 0 V 0Vsens N/C A $\bar{A}$ B $\bar{B}$ C+ C- D+ D- N/C N/C N/C
			Pin: 1 2 3 4 5 6 7 8 9 10 11 12 13 14 15 16
Interface	Type of connection	Features	Tangential cable, with Sub-D connector (male contact), 15-pin
E	G	SinCos sensor output	Signal: A 0 V B +V D+ - - C+ $\bar{A}$ 0Vsens $\bar{B}$ +Vsens D- - C- $\perp$
			Pin: 1 2 3 4 5 6 7 8 9 10 11 12 13 14 15
Interface	Type of connection	Features	PCB connector (male contact), 12-pin
6, E	L	SinCos sensor output	Signal: D- +V A C+ 0Vsens $\bar{B}$ B 0 V C- $\bar{A}$ +Vsens D+
			Pin: 1a 1b 2a 2b 3a 3b 4a 4b 5a 5b 6a 6b
Interface	Type of connection	Features	PCB connector (male contact), 12-pin
1, 2	L	SET, DIR	Signal: D- +V - C+ DIR - - 0 V C- - SET D+
			Pin: 1a 1b 2a 2b 3a 3b 4a 4b 5a 5b 6a 6b
Interface	Type of connection	Features	PCB connector (male contact), 12-pin
3, 4	L	SET, DIR, SinCos	Signal: D- +V A C+ DIR $\bar{B}$ B 0 V C- $\bar{A}$ SET D+
			Pin: 1a 1b 2a 2b 3a 3b 4a 4b 5a 5b 6a 6b
Interface	Type of connection	Features	PCB connector (male contact), 12-pin
5	L	sensor output	Signal: D- +V - C+ 0Vsens - - 0 V C- - +Vsens D+
			Pin: 1a 1b 2a 2b 3a 3b 4a 4b 5a 5b 6a 6b

- +V: Encoder power supply +V DC
- 0 V: Encoder power supply ground GND (0 V)
- 0 Vsens / +Vsens: Using the sensor outputs of the encoder, the voltage present can be measured and if necessary increased accordingly.
- C+, C-: Clock signal
- D+, D-: Data signal
- A,  $\bar{A}$ : Incremental output channel A (cosine)
- B,  $\bar{B}$ : Incremental output channel B (sine)
- SET: Set input
- DIR: Direction input
- Stat: Status output
- PH  $\perp$ : Plug connector housing (shield)

### Top view of mating side, male contact base

Type of connection H  
Phoenix Contact connector (MC1.5/16-STF-3.81), 16-pin



Type of connection G  
Sub-D connector (male contact), double-row, 15-pin

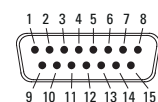

Type of connection L  
FCI Minitek connector (male contact), double-row, 12-pin (98424-F52-12-LF)

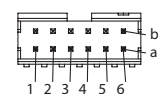

## Terminal assignment cordset 8.0000.6D91.0002 or 8.0000.6D91.0008

PCB connector (female contacts), 12-pin / single-ended												
Pin:	1a	1b	2a	2b	3a	3b	4a	4b	5a	5b	6a	6b
Core color:	PK	BN	BU	GN	GY-PK	VT	BK	WH	YE	RD	RD-BU	GY

# Absolute encoders - singleturn

**Standard  
Motor-Line, optical**

**Sendix 5873 (tapered shaft)**

**SSI / BiSS + incremental**

## Dimensions tapered shaft version

Dimensions in mm [inch]

### Flange with stator coupling, $\varnothing 72$ [2.83]

#### Flange type G

(with tapered shaft K and tangential cable)

- 1 Recommended torque for screw M6 (SW 4) 2.0  $^{+0.5}$  Nm
- 2 Recommended torque for tightening screw M6 (SW 4) 3.0  $^{+0.5}$  Nm
- 3 Sealing cap for tangential cable outlet

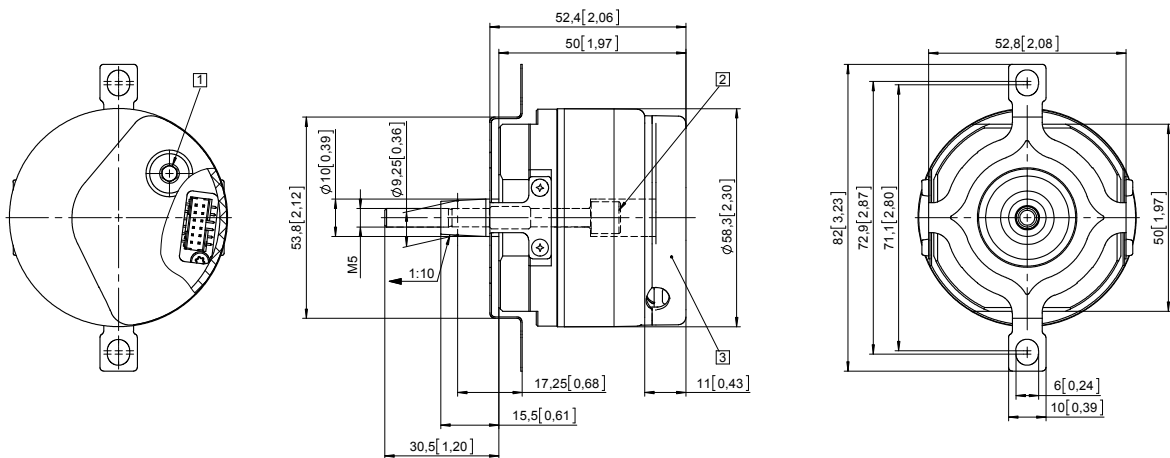

### Flange with expanding coupling,

$\varnothing 65$  [2.56"]

#### Flange type H

- 1 Status-LED
- 2 SET button
- 3 Recommended torque for (SW 4) tightening screw 3  $^{+0.5}$  Nm
- 4 Recommended torque for (SW 2) tightening screw 1 Nm

