

# Absolute encoders – multiturn

Standard, ATEX/IECEX – zone 1/21  
mechanical multiturn, optical

Sendix 7068 / 7088 (shaft / hollow shaft)

CANopen



The Sendix 7068 / 7088 absolute multiturn encoders offer Ex protection in a compact 70 mm seawater durable aluminum housing, with a CANopen interface and optical sensor technology. These shock and vibration-resistant encoders operate flexibly with a resolution of up to 28 bits; they are also available with axial and radial cable outlets.

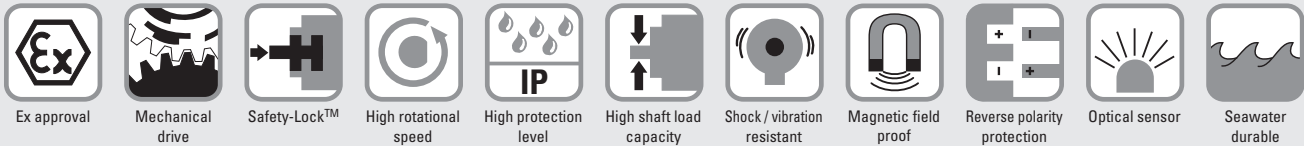

## Compact and safe

- Can be used even when space is tight.
- Minimal installation depth, diameter 70 mm.
- Compact cable outlet axial or radial.
- Can be operated in marine environments – housing and flange manufactured from seawater durable aluminum.
- Remains sealed even in harsh everyday use and ensures highest safety against field breakdowns (IP67 protection).

## Explosion protection

- “Flameproof-enclosure” version.
- ATEX with EC type examination certificate.
- IECEx with certificate of conformity (CoC).

## Order code Shaft version

8.7068 . 1 X 2 X . 21 21 . XXXX  
Type      a   b   c   d      e      f <sup>1)</sup>

### a Flange

1 = clamping / synchronous flange, IP67, ø 70 mm [2.76"]

### b Shaft (ø x L)

2 = 10 x 20 mm [0.39 x 0.79"], with flat  
1 = 12 x 25 mm [0.47 x 0.98"], with keyway  
for 4 x 4 mm [0.16 x 0.16"] key

### c Interface / power supply

2 = CANopen DS301 V4.02 / 10 ... 30 V DC

### d Type of connection

1 = axial cable, 2 m [6.56'] PUR  
2 = radial cable, 2 m [6.56'] PUR  
A = axial cable, length > 2 m [6.56']  
B = radial cable, length > 2 m [6.56']

### e Fieldbus profile

21 = CANopen

### f Cable length in dm <sup>1)</sup>

0050 = 5 m [16.40']  
0100 = 10 m [32.81']  
0150 = 15 m [49.21']

### Optional on request

- special cable length
- IP65 version for T6
- seawater resistant (stainless steel V4A)

### Stainless steel V4A as standard types (deliverable as from 1 unit)

8.7068.1221.2121.V4A  
8.7068.122A.2121.XXXX-V4A



1) Not applicable with connection types 1 and 2.

# Absolute encoders – multiturn

<b>Standard, ATEX/IECEX – zone 1/21 mechanical multiturn, optical</b>	<b>Sendix 7068 / 7088 (shaft / hollow shaft)</b>	<b>CANopen</b>
---	--	----------------

<b>Order code</b> <b>Hollow shaft</b>	<b>8.7088</b> Type	<b>.XX2X</b> a b c d	<b>.2121</b> e	<b>.XXXX</b> f 1)
<b>a Flange</b> 1 = with spring element, short 5 = with stator coupling, IP67, ø 65 mm [2.56"]	<b>d Type of connection</b> 1 = axial cable, 2 m [6.56'] PUR 2 = radial cable, 2 m [6.56'] PUR A = axial cable, length > 2 m [6.56'] B = radial cable, length > 2 m [6.56']	<b>Optional on request</b> - special cable length - IP65 version for T6 - seawater resistant (stainless steel V4A)		
<b>b Blind hollow shaft</b> (insertion depth max. 41.5 mm [1.63"]) 1 = ø 12 mm [0.47"] 2 = ø 14 mm [0.55"]	<b>e Fieldbus profile</b> 21 = CANopen	<b>Stainless steel V4A as standard types</b> (deliverable as from 1 unit) 8.7088.1221.2121.V4A 8.7088.122A.2121.XXXX-V4A		
<b>c Interface / power supply</b> 2 = CANopen DS301 V4.02 / 10 ... 30 V DC	<b>f Cable length in dm 1)</b> 0050 = 5 m [16.40'] 0100 = 10 m [32.81'] 0150 = 15 m [49.21']	<b>V4A</b> 1.4404		

<b>Mounting accessory for shaft encoders</b>	<b>Order no.</b>
<b>Coupling</b> bellows coupling ø 19 mm [0.75"] for shaft 10 mm [0.39"]	<b>8.0000.1102.1010</b>

Further accessories can be found in the accessories section or in the accessories area of our website at: [www.kuebler.com/accessories](http://www.kuebler.com/accessories).  
Additional connectors can be found in the connection technology section or in the connection technology area of our website at: [www.kuebler.com/connection\\_technology](http://www.kuebler.com/connection_technology).

## Technical data

Explosion protection Sendix 7068	
<b>ATEX</b>	
<b>EC type-examination certificate</b>	PTB09 ATEX 1106 X
<b>Category (gas)</b>	II 2 G Ex d IIC T4 - T6 Gb
<b>Category (dust)</b>	II 2D Ex tb IIIC T135°C - T85°C Db
<b>Relevant standards</b> ATEX guideline 94/9/EC	EN 60079-0:2012; EN 60079-1:2014; EN 60079-31:2009
<b>IECEX</b>	
<b>Certificate of Conformity (CoC)</b>	IECEX PTB 13.0026 X
<b>Category (gas)</b>	Ex d IIC T4 - T6 Gb
<b>Category (dust)</b>	Ex tb IIIC T135°C - T85°C Db
<b>Relevant standards</b>	IEC 60079-0:2011; IEC 60079-1:2014; IEC 60079-31:2008

Explosion protection Sendix 7088	
<b>ATEX</b>	
<b>EU type-examination certificate</b>	IBExU 15 ATEX 1091 X
<b>Category (gas)</b>	II 2 G Ex db IIC T4/120°C (T4)/T6 Gb
<b>Category (dust)</b>	II 2 D Ex tb IIIC T135°C - T85°C Db
<b>Relevant standards</b> ATEX guideline 2014/34/EU	EN 60079-0:2012 + A11:2013; EN 60079-1:2014; EN 60079-31:2014
<b>IECEX</b>	
<b>Certificate of Conformity (CoC)</b>	IECEX IBE 15.0020 X
<b>Category (gas)</b>	Ex db IIC T4/120°C (T4)/T6 Gb
<b>Category (dust)</b>	Ex tb IIIC T135°C - T85°C Db
<b>Relevant standards</b>	IEC 60079-0:2011; IEC 60079-1:2014; IEC 60079-31:2013

Mechanical characteristics	
<b>Maximum speed</b>	shaft 6000 min <sup>-1</sup> (continuous) hollow shaft 3000 min <sup>-1</sup> (continuous)
<b>Starting torque – at 20°C [68°F]</b>	< 0.05 Nm
<b>Mass moment of inertia</b>	4.0 x 10 <sup>-6</sup> kgm <sup>2</sup>
<b>Load capacity of shaft</b>	radial 80 N axial 40 N
<b>Weight</b>	approx. 1.5 kg [52.91 oz]
<b>Protection acc. to EN 60529</b>	IP67
<b>Ambient temperature</b>	-40°C ... +60°C [-40 ... +140°F] please note the specifications for temperature class in EC type-examination certificate!
<b>Material</b>	shaft stainless steel flange / housing seawater durable Al, type AlSiMgMn (EN AW-6082) cable PUR
<b>Shock resistance to EN/IEC 60068-2-27</b>	2500 m/s <sup>2</sup> , 6 ms
<b>Vibration resistance to EN/IEC 60068-2-6</b>	100 m/s <sup>2</sup> , 55 ... 2000 Hz

Electrical characteristics	
<b>Power supply</b>	10 ... 30 V DC
<b>Current consumption (no load)</b>	max. 100 mA
<b>Reverse polarity protection for power supply</b>	yes
<b>CE compliant acc. to</b>	EMC guideline 2014/30/EU RoHS guideline 2011/65/EU

EMC	
<b>Relevant standards</b>	EN 55011 class B:2009 / A1:2010 EN 61000-6-2:2005 / AC:2005 EN 61000-6-3:2007 / A1:2011 EN 61326-1:2013

# Absolute encoders – multiturn

<b>Standard, ATEX/IECEX – zone 1/21 mechanical multiturn, optical</b>	<b>Sendix 7068 / 7088 (shaft / hollow shaft)</b>	<b>CANopen</b>
---	--	----------------

Interface characteristics CANopen	
<b>Resolution singleturn</b>	1 ... 65535 (16 bit), scalable default: 8192 (13 bit)
<b>Number of revolutions (multiturn)</b>	max. 4096 (12 bit) scalable only via the total resolution
<b>Total resolution</b>	1 ... 268.435.456 (28 bit), scalable default: 33.554.432 (25 bit)
<b>Code</b>	binary
<b>Interface</b>	CAN high-speed acc. to ISO 11898, Basic- and Full-CAN, CAN specification 2.0 B
<b>Protocol</b>	CANopen profile DS406 V3.2 with manufacturer-specific add-ons
<b>Baud rate</b>	10 ... 1000 kbit/s software configurable
<b>Node address</b>	1 ... 127 software configurable
<b>Switchable termination</b>	software configurable

### General information about CANopen

The CANopen encoders support the latest CANopen communication profile according to DS301 V4.02. In addition, device-specific profiles like the encoder profile DS406 V3.2 are available.

The following operating modes may be selected: Polled Mode, Cyclic Mode, Sync Mode and a High Resolution Sync Protocol. Moreover, scale factors, preset values, limit switch values and many other additional parameters can be programmed via the CANbus. When switching the device on, all parameters are loaded from an EEPROM, where they were saved previously to protect them against power-failure.

As output values **position, speed, acceleration** as well as the **working area status** may be combined freely as PDO (PDO mapping)

### CANopen communication profile DS301 V4.02

Among others, the following functionality is integrated:

Class C2 functionality

- NMT slave.
- Heartbeat protocol.
- High resolution sync protocol.
- Identity object.
- Error behavior object.
- Variable PDO mapping self-start programmable (power on to operational), 3 Sending PDO's.
- Node address, baud rate and CANbus programmable termination.

### CANopen encoder profile DS406 V3.2

The following parameters can be programmed:

- Event mode.
- Units for speed selectable (steps/sec or min<sup>-1</sup>).
- Factor for speed calculation (e.g. measuring wheel circumference)  
Integration time for speed value of 1...32.
- 2 work areas with 2 upper and lower limits and the corresponding output states.
- Variable PDO mapping of position, speed, acceleration, working area status.
- Extended failure management for position sensing with integrated temperature control.
- User interface with visual display of bus and failure status - 3 LED's.
- Optional - 32 CAMs programmable.
- Customer-specific memory - 16 Bytes.

### Universal scaling function

At the end of the physical resolution of an encoder, **when scaling is active**, an error appears if the division of the physical limit (GP\_U) by the programmed total resolution (TMR) does not produce an integer.

The universal scaling function remedies this problem.

### Terminal assignment

Interface	Type of connection	Cable (isolate unused wires individually before initial start-up)								
		Signal:	0 V	+V	CAN_H	CAN_L	CAN_GND	CAN_H	CAN_L	CAN_GND
2	1, 2, A, B	Signal:	0 V	+V	CAN_H	CAN_L	CAN_GND	CAN_H	CAN_L	CAN_GND
		Cable marking:	1	2	4	5	6	7	8	9

# Absolute encoders – multiturn

<b>Standard, ATEX/IECEx – zone 1/21 mechanical multiturn, optical</b>	<b>Sendix 7068 / 7088 (shaft / hollow shaft)</b>	<b>CANopen</b>
---	--	----------------

## Dimensions shaft version

Dimensions in mm [inch]

### Clamping / synchronous flange, $\varnothing$ 70 [2.76]

#### Shaft type 1 with axial cable outlet

- 1 9 x M4, 10 [0.39] deep
- 2 Keyway for DIN 6885-A-4x4x25 key

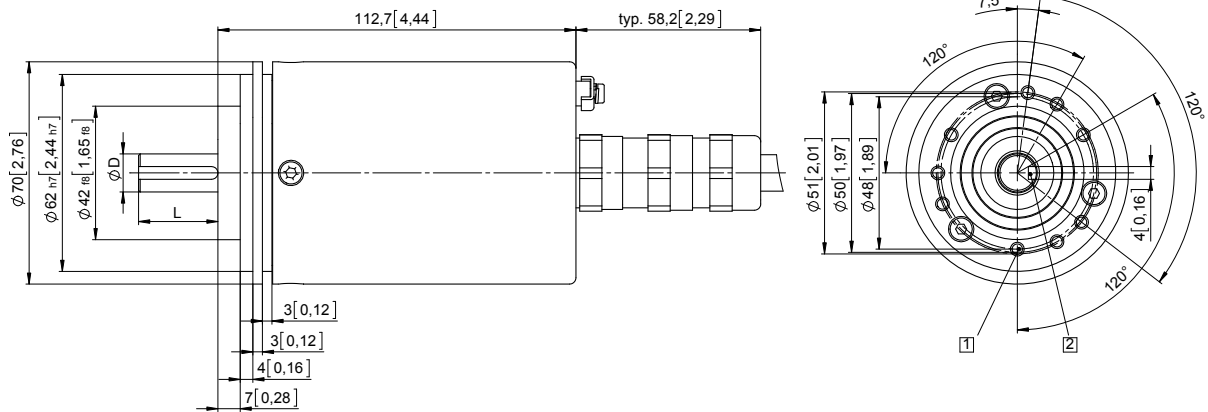

D	Fit	L
12 [0.47]	g6	25 [0.98]

### Clamping / synchronous flange, $\varnothing$ 70 [2.76]

#### Shaft type 2 with radial cable outlet

- 1 9 x M4, 10 [0.39] deep

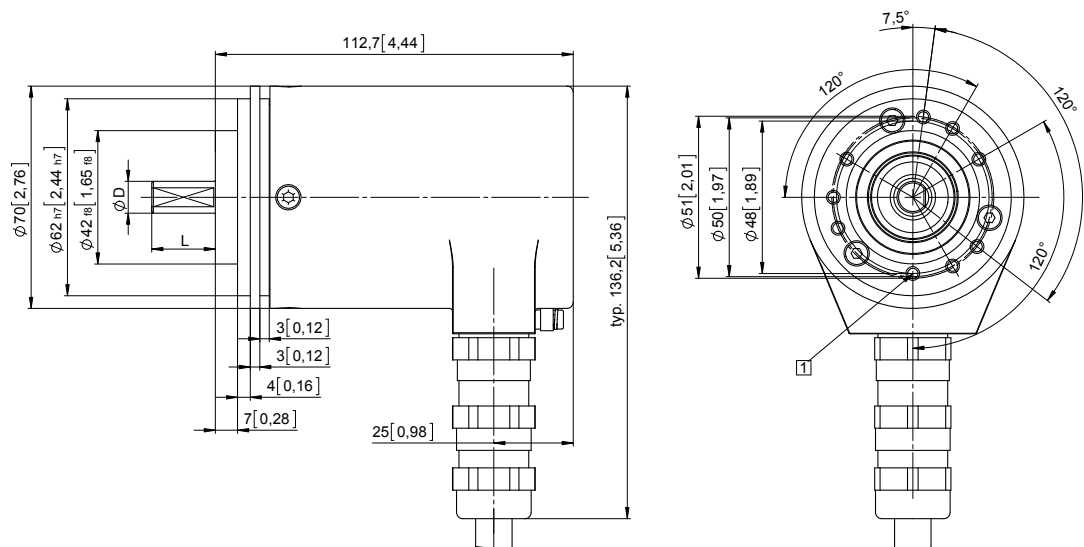

D	Fit	L
10 [0.39]	f7	20 [0.79]

# Absolute encoders – multiturn

**Standard, ATEX/IECEx – zone 1/21  
mechanical multiturn, optical**

**Sendix 7068 / 7088 (shaft / hollow shaft)**

**CANopen**

## Dimensions hollow shaft version

Dimensions in mm [inch]

### Flange with spring element, short Flange type 1

- 1 9 x M4, 10 [0.39] deep
- 2 Slot spring element, recommendation: cylindrical pin DIN 7,  $\varnothing 4$  [0.16]
- 3 Recommended torque for the clamping ring 2.5 Nm

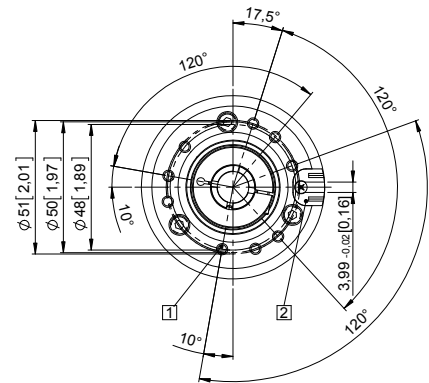
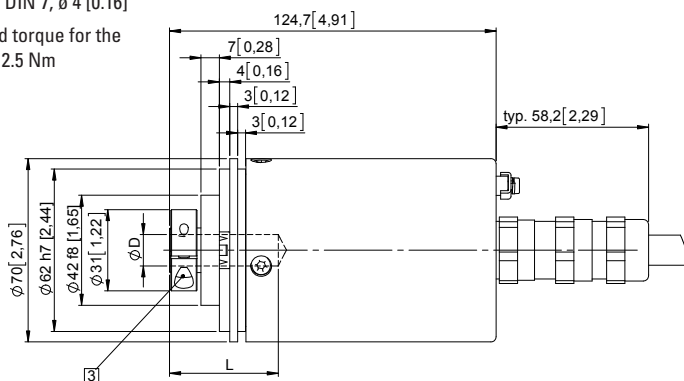

D	Fit	L
12 [0.47]	H7	41.5 [1.63"]
14 [0.55]	H7	41.5 [1.63"]

L = insertion depth max. blind hollow shaft

### Flange with stator coupling, $\varnothing 65$ [2.56]

#### Flange type 5

- 1 Recommended torque for the clamping ring 2.5 Nm

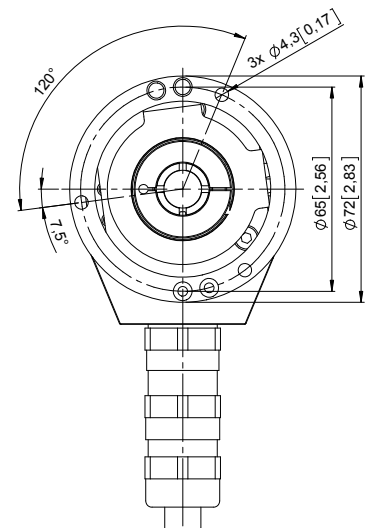
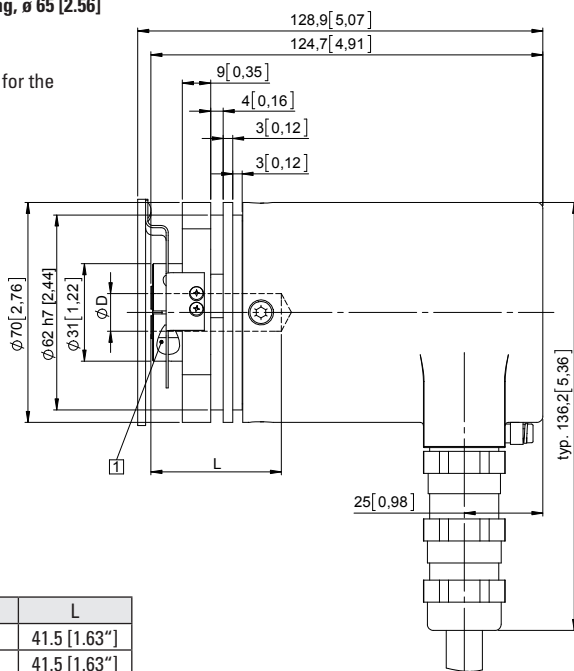

D	Fit	L
12 [0.47]	H7	41.5 [1.63"]
14 [0.55]	H7	41.5 [1.63"]

L = insertion depth max. blind hollow shaft