

# Absolute encoders – multiturn

Standard, ATEX/IECEX – zone 1/21  
mechanical multiturn, optical

Sendix 7063 / 7083 (shaft / hollow shaft)

SSI / BiSS



The Sendix 7063 / 7083 absolute multiturn encoders offer Ex protection in a compact 70 mm seawater durable aluminum housing, with an SSI or BiSS interface and optical sensor technology.

These shock and vibration-resistant encoders operate flexibly with a resolution of up to 29 bits; they are also available with axial and radial cable outlets.

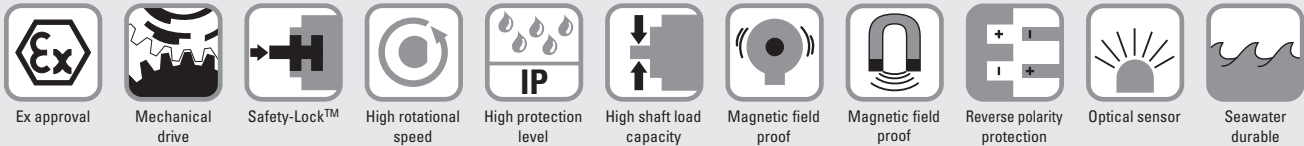

## Compact and safe

- Can be used even when space is tight.
- Minimal installation depth, diameter 70 mm.
- Compact cable outlet axial or radial.
- Can be operated in marine environments – housing and flange manufactured from seawater durable aluminum.
- Remains sealed even in harsh everyday use and ensures highest safety against field breakdowns (IP67 protection).

## Explosion protection

- “Flameproof-enclosure” version.
- ATEX with EC type examination certificate.
- IECEx with certificate of conformity (CoC).

## Order code Shaft version

8.7063 . 1 X 2 X . X X 2 1 . XXXX  
Type      a b c d e f g h i <sup>1)</sup>

- a** Flange  
1 = clamping / synchronous flange, IP67, ø 70 mm [2.76"]
- b** Shaft (ø x L)  
2 = 10 x 20 mm [0.39 x 0.79"], with flat  
1 = 12 x 25 mm [0.47 x 0.98"],  
with keyway for 4 x 4 mm [0.16 x 0.16"] key
- c** Interface / power supply  
2 = SSI, BiSS / 10 ... 30 V DC
- d** Type of connection  
1 = axial cable, 2 m [6.56'] PUR  
2 = radial cable, 2 m [6.56'] PUR  
A = axial cable, length > 2 m [6.56']  
B = radial cable, length > 2 m [6.56']

- e** Code  
B = SSI, binary  
C = BiSS, binary  
G = SSI, gray
- f** Resolution <sup>2)</sup>  
A = 10 bit ST + 12 bit MT  
1 = 11 bit ST + 12 bit MT  
2 = 12 bit ST + 12 bit MT  
3 = 13 bit ST + 12 bit MT  
4 = 14 bit ST + 12 bit MT  
7 = 17 bit ST + 12 bit MT
- g** Inputs / outputs <sup>2)</sup>  
2 = SET, DIR input  
additional status output
- h** Options  
1 = no option

- i** Cable length in dm <sup>1)</sup>  
0050 = 5 m [16.40']  
0100 = 10 m [32.81']  
0150 = 15 m [49.21']
- Optional on request*  
- special cable length  
- other singleturn resolutions  
- IP65 version for T6  
- seawater resistant (stainless steel V4A)
- Stainless steel V4A as standard types  
(deliverable as from 1 unit)*
- |               |                           |
|---------------|---------------------------|
| V4A<br>1.4404 | 8.7063.1221.XX21.V4A      |
|               | 8.7063.122A.XX21.XXXX-V4A |

1) Not applicable with connection types 1 and 2.  
2) Resolution, preset value and counting direction factory-programmable.

# Absolute encoders – multiturn

<b>Standard, ATEX/IECEX – zone 1/21 mechanical multiturn, optical</b>	<b>Sendix 7063 / 7083 (shaft / hollow shaft)</b>	<b>SSI/BiSS</b>
---	--	-----------------

<b>Order code</b> <b>Hollow shaft</b>	<b>8.7083</b> Type	<b>.XX2X.XX21.XXXX</b> a b c d e f g h i <sup>1)</sup>
<b>a Flange</b> 1 = with spring element, short 5 = with stator coupling, IP67, ø 65 mm [2.56"]	<b>e Code</b> B = SSI, binary C = BiSS, binary G = SSI, gray	<b>i Cable length in dm <sup>1)</sup></b> 0050 = 5 m [16.40'] 0100 = 10 m [32.81'] 0150 = 15 m [49.21']
<b>b Blind hollow shaft</b> (insertion depth max. 41.5 mm [1.63"]) 1 = ø 12 mm [0.47"] 2 = ø 14 mm [0.55"]	<b>f Resolution <sup>2)</sup></b> A = 10 bit ST + 12 bit MT 1 = 11 bit ST + 12 bit MT 2 = 12 bit ST + 12 bit MT 3 = 13 bit ST + 12 bit MT 4 = 14 bit ST + 12 bit MT 7 = 17 bit ST + 12 bit MT	<b>Optional on request</b> - special cable length - other singleturn resolutions - IP65 version for T6 - seawater resistant (stainless steel V4A)
<b>c Interface / power supply</b> 2 = SSI, BiSS / 10 ... 30 V DC	<b>g Inputs / outputs <sup>2)</sup></b> 2 = SET, DIR input additional status output	<b>Stainless steel V4A as standard types</b> (deliverable as from 1 unit) 8.7083.1221.XX21-V4A 8.7083.122A.XX21.XXXX-V4A
<b>d Type of connection</b> 1 = axial cable, 2 m [6.56'] PUR 2 = radial cable, 2 m [6.56'] PUR A = axial cable, length > 2 m [6.56'] B = radial cable, length > 2 m [6.56']	<b>h Options</b> 1 = no option	<b>V4A</b> 1.4404

<b>Mounting accessory for shaft encoders</b>	<b>Order no.</b>
<b>Coupling</b> bellows coupling ø 19 mm [0.75"] for shaft 10 mm [0.39"]	<b>8.0000.1102.1010</b>

Further accessories can be found in the accessories section or in the accessories area of our website at: [www.kuebler.com/accessories](http://www.kuebler.com/accessories).  
Additional connectors can be found in the connection technology section or in the connection technology area of our website at: [www.kuebler.com/connection\\_technology](http://www.kuebler.com/connection_technology).

## Technical data

Explosion protection Sendix 7063	
<b>ATEX</b>	
<b>EC type-examination certificate</b>	PTB09 ATEX 1106 X
<b>Category (gas)</b>	II 2 G Ex d IIC T4 - T6 Gb
<b>Category (dust)</b>	II 2D Ex tb IIIC T135°C - T85°C Db
<b>Relevant standards</b> ATEX guideline 94/9/EC	EN 60079-0:2012; EN 60079-1:2014; EN 60079-31:2009
<b>IECEX</b>	
<b>Certificate of Conformity (CoC)</b>	IECEX PTB 13.0026 X
<b>Category (gas)</b>	Ex d IIC T4 - T6 Gb
<b>Category (dust)</b>	Ex tb IIIC T135°C - T85°C Db
<b>Relevant standards</b>	IEC 60079-0:2011; IEC 60079-1:2014; IEC 60079-31:2008

Explosion protection Sendix 7083	
<b>ATEX</b>	
<b>EU type-examination certificate</b>	IBExU 15 ATEX 1091 X
<b>Category (gas)</b>	II 2 G Ex db IIC T4/120°C (T4)/T6 Gb
<b>Category (dust)</b>	II 2 D Ex tb IIIC T135°C - T85°C Db
<b>Relevant standards</b> ATEX guideline 2014/34/EU	EN 60079-0:2012 + A11:2013; EN 60079-1:2014; EN 60079-31:2014
<b>IECEX</b>	
<b>Certificate of Conformity (CoC)</b>	IECEX IBE 15.0020 X
<b>Category (gas)</b>	Ex db IIC T4/120°C (T4)/T6 Gb
<b>Category (dust)</b>	Ex tb IIIC T135°C - T85°C Db
<b>Relevant standards</b>	IEC 60079-0:2011; IEC 60079-1:2014; IEC 60079-31:2013

Electrical characteristics	
<b>Power supply</b>	10 ... 30 V DC
<b>Current consumption (no load)</b>	max. 45 mA
<b>Reverse polarity protection for power supply</b>	yes
<b>Short-circuit proof outputs</b>	yes <sup>3)</sup>
<b>CE compliant acc. to</b>	EMC guideline 2014/30/EU RoHS guideline 2011/65/EU

EMC	
<b>Relevant standards</b>	EN 55011 class B:2009 / A1:2010 EN 61000-6-2:2005 / AC:2005 EN 61000-6-3:2007 / A1:2011 EN 61326-1:2013

1) Not applicable with connection types 1 and 2.  
2) Resolution, preset value and counting direction factory-programmable.  
3) Short-circuit with 0 V or output, only one channel at a time, power supply correctly applied.

Absolute encoders  
multiturn

# Absolute encoders – multiturn

<b>Standard, ATEX/IECEX – zone 1/21 mechanical multiturn, optical</b>	<b>Sendix 7063 / 7083 (shaft / hollow shaft)</b>	<b>SSI/BiSS</b>
---	--	-----------------

Mechanical characteristics		
<b>Maximum speed</b>	shaft	6000 min <sup>-1</sup> (continuous)
	hollow shaft	3000 min <sup>-1</sup> (continuous)
<b>Starting torque – at 20°C [68°F]</b>	< 0.05 Nm	
<b>Mass moment of inertia</b>	4.0 x 10 <sup>-6</sup> kgm <sup>2</sup>	
<b>Load capacity of shaft</b>	radial	80 N
	axial	40 N
<b>Weight</b>	approx. 1.5 kg [52.91 oz]	
<b>Protection acc. to EN 60529</b>	IP67	
<b>Ambient temperature</b>	-40°C ... +60°C [-40 ... +140°F] p lease note the specifications for temperature class in EC type-examination certificate!	
<b>Material</b>	shaft	stainless steel
	flange / housing	seawater durable Al, type AlSiMgMn (EN AW-6082)
	cable	PUR
<b>Shock resistance</b>	acc. to EN/IEC 60068-2-27 2500 m/s <sup>2</sup> , 6 ms	
<b>Vibration resistance</b>	acc. to EN/IEC 60068-2-6 100 m/s <sup>2</sup> , 55 ... 2000 Hz	

Status output		
<b>Output driver</b>	open collector, internal pull-up resistor 22 kOhm	
<b>Permissible load</b>	max. 20 mA	
<b>Signal level</b>	HIGH	+V
	LOW	< 1 V
<b>Active at</b>	LOW	
The status output serves to display various alarm or error messages. The status output is HIGH (open collector with internal pull-up 22 kOhm) in normal operation.		

SET input		
<b>Input</b>	HIGH active	
<b>Input type</b>	comparator	
<b>Signal level</b> (+V = Power supply)	HIGH	min. 60 % of +V max. +V
	LOW	max. 25 % of +V
<b>Input current</b>	< 0.5 mA	
<b>Min. pulse duration (SET)</b>	10 ms	
<b>Timeout after SET signal</b>	14 ms	
The encoder can be set to zero at any position by means of a HIGH signal on the SET input. Other preset values can be factory-programmed. The SET input has a signal delay time of approximately 1 ms. Once the SET function has been triggered, the encoder requires an internal processing time of approximately 15 ms before the new position data can be read. If this input is not used, it should be connected to 0 V (Encoder ground GND) in order to avoid interferences.		

SSI interface		
<b>Output driver</b>	RS485 transceiver type	
<b>Permissible load / channel</b>	max. +/- 20 mA	
<b>Signal level</b>	HIGH	typ 3.8 V
	LOW at I <sub>Load</sub> = 20 mA	typ 1.3 V
<b>Resolution singleturn</b>	10 ... 14 bit and 17 bit	
<b>Number of revolutions (multiturn)</b>	4096 (12 bit)	
<b>Code</b>	binary or gray	
<b>SSI clock rate</b>	50 kHz ... 2 MHz	
<b>Data refresh rate</b>	ST resolution ≤ 14 bit	≤ 1 μs
	ST resolution ≥ 15 bit	4 μs
<b>Monoflop time</b>	≤ 15 μs <sup>2)</sup>	
<b>Note:</b> if clock starts cycling within monoflop time a second data transfer starts with the same data. If clock starts cycling after monoflop time, the data transfer starts with updated values. The update rate depends on clock speed, data length and monoflop time.		

BiSS interface		
<b>Resolution singleturn</b>	10 ... 14 bit and 17 bit	
<b>Number of revolutions (multiturn)</b>	4096 (12 bit)	
<b>Code</b>	binary	
<b>Clock rate</b>	up to 10 MHz	
<b>Max. update rate</b>	< 10 μs, depends on the clock rate and the data length	
<b>Data refresh rate</b>	ST resolution ≤ 14 bit	≤ 1 μs
	ST resolution 17 bit	2.4 μs
<b>Note:</b>	– bidirectional, factory programmable parameters are: resolution, code, direction, alarms, warnings – CRC data verification	

DIR input	
Direction input: A HIGH signal switches the direction of rotation from the default cw to ccw. This inverted function can also be factory-programmed. If DIR is reversed when the device is already switched on, this will be interpreted as an error. The status output switches to LOW. If this input is not used, it should be connected to 0 V (Encoder ground GND) in order to avoid interferences.	
<b>Response time (DIR input)</b>	1 ms

Power-ON	
After Power-ON the device requires a time of approx. 150 ms before valid data can be read.	
Hot plugging of the encoder should be avoided.	

### Terminal assignment

Interface	Type of connection	Features	Cable (isolate unused wires individually before initial start-up)												
			Signal:	0 V	+V	C+	C-	D+	D-	SET	DIR	Stat	⊕	⊖	
2	1, 2, A, B	SET, DIR	Cable marking:	1	2	3	4	5	6	7	8	9	YE/GN	shield	

+V: Encoder power supply +V DC  
 0 V: Encoder power supply ground GND (0 V)  
 C+, C-: Clock signal  
 D+, D-: Data signal

SET: Set input  
 DIR: Direction input  
 Stat: Status output  
 ⊕: Protective earth

# Absolute encoders – multiturn

<b>Standard, ATEX/IECEX – zone 1/21 mechanical multiturn, optical</b>	<b>Sendix 7063 / 7083 (shaft / hollow shaft)</b>	<b>SSI/BiSS</b>
---	--	-----------------

## Dimensions shaft version

Dimensions in mm [inch]

### Clamping / synchronous flange, $\varnothing$ 70 [2.76]

#### Shaft type 1 with axial cable outlet

- 1 9 x M4, 10 [0.39] deep
- 2 Keyway for DIN 6885-A-4x4x25 key

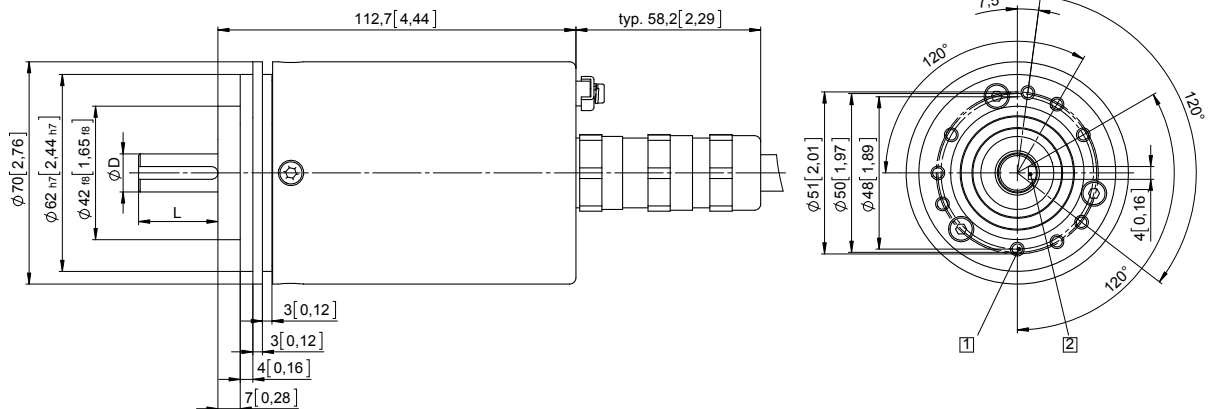

D	Fit	L
12 [0.47]	g6	25 [0.98]

### Clamping / synchronous flange, $\varnothing$ 70 [2.76]

#### Shaft type 2 with radial cable outlet

- 1 9 x M4, 10 [0.39] deep

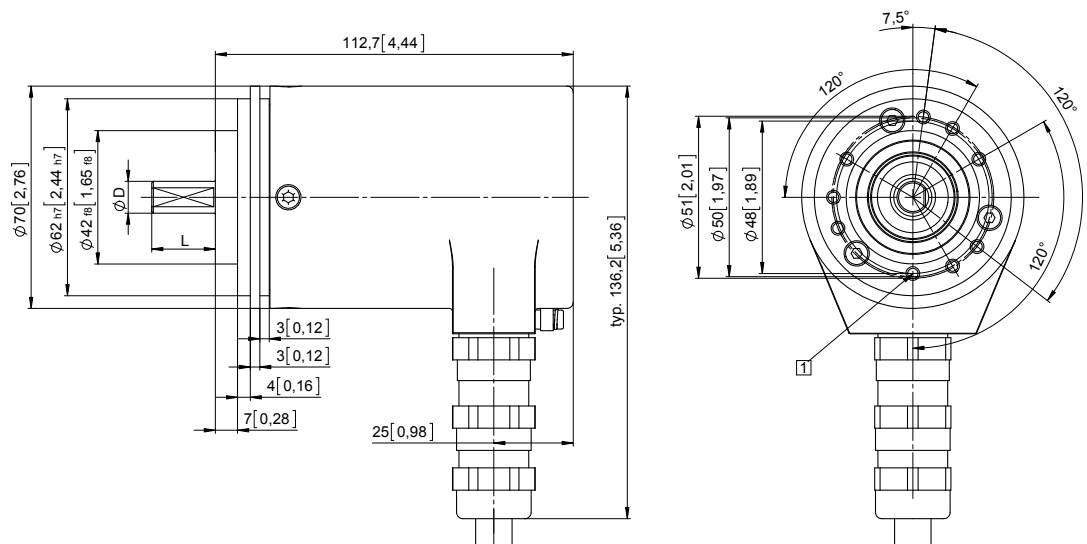

D	Fit	L
10 [0.39]	f7	20 [0.79]

# Absolute encoders – multiturn

**Standard, ATEX/IECEx – zone 1/21  
mechanical multiturn, optical**

**Sendix 7063 / 7083 (shaft / hollow shaft)**

**SSI / BiSS**

## Dimensions hollow shaft version

Dimensions in mm [inch]

### Flange with spring element, short Flange type 1

- 1 9 x M4, 10 [0.39] deep
- 2 Slot spring element, recommendation: cylindrical pin DIN 7,  $\varnothing 4$  [0.16]
- 3 Recommended torque for the clamping ring 2.5 Nm

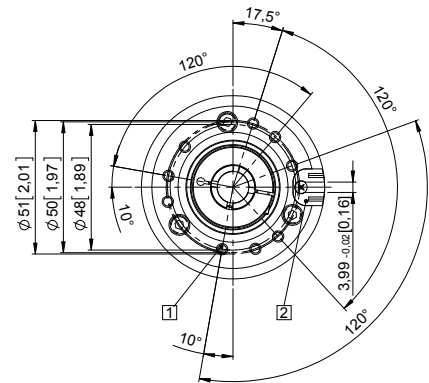
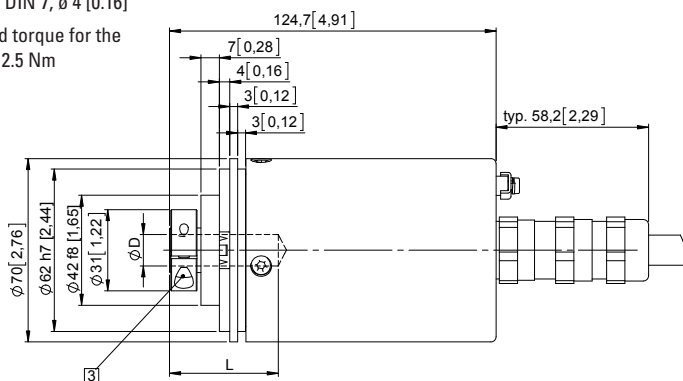

D	Fit	L
12 [0.47]	H7	41.5 [1.63"]
14 [0.55]	H7	41.5 [1.63"]

L = insertion depth max. blind hollow shaft

### Flange with stator coupling, $\varnothing 65$ [2.56]

#### Flange type 5

- 1 Recommended torque for the clamping ring 2.5 Nm

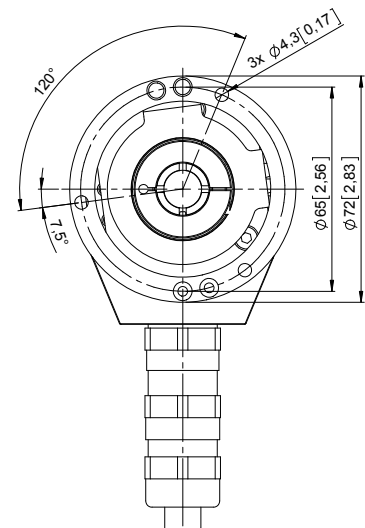
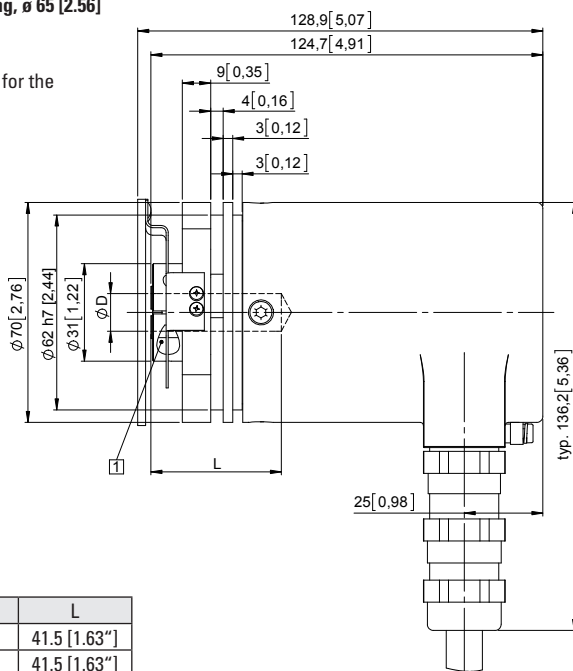

D	Fit	L
12 [0.47]	H7	41.5 [1.63"]
14 [0.55]	H7	41.5 [1.63"]

L = insertion depth max. blind hollow shaft